

PAC-E

The new all-electric high-speed benchmark

Arnaud Nombrot | 31.08.2022

1

Sumitomo (SHI) Demag

Company introduction

Our Company | Sumitomo Heavy Industries



Sumitomo Heavy Industries (SHI)

Head Office: Shinagawa/Tokyo, Japan

Foundation: 1888

Employees: 24.500

- Roots of all Sumitomo companies go back to 1630
- All key components are developed and produced by SHI in-house
- Manufacturing excellence: from nanotechnology to enormous steel structures



Machinery
Components



Precision
Machinery



Construction
Machinery

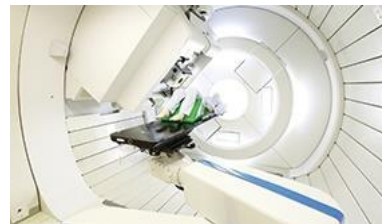

Industrial
Machinery



Ships



Environmental
Facilities & Plants

Our Company | Sumitomo (SHI) Demag



70

Years of Experience



3.000

Employees Globally

- 4** Production Facilities
- 30** Subsidiaries

149.000

Installed Machines
Worldwide



71.000

All-Electric Machines Worldwide

7.000 IMM/Year

800

Million € Turnover



Our Company | Industries



Packaging



Automotive



Electronics



Medical



Consumer

Our Company | Focus on packaging applications



Thin wall & In-mould labeling



Beverage Caps



Industrial buckets



Others

2

PAC-E

The new all-electric high-speed benchmark

Packaging | PAC-E origin

Clamping Force < 450 tons

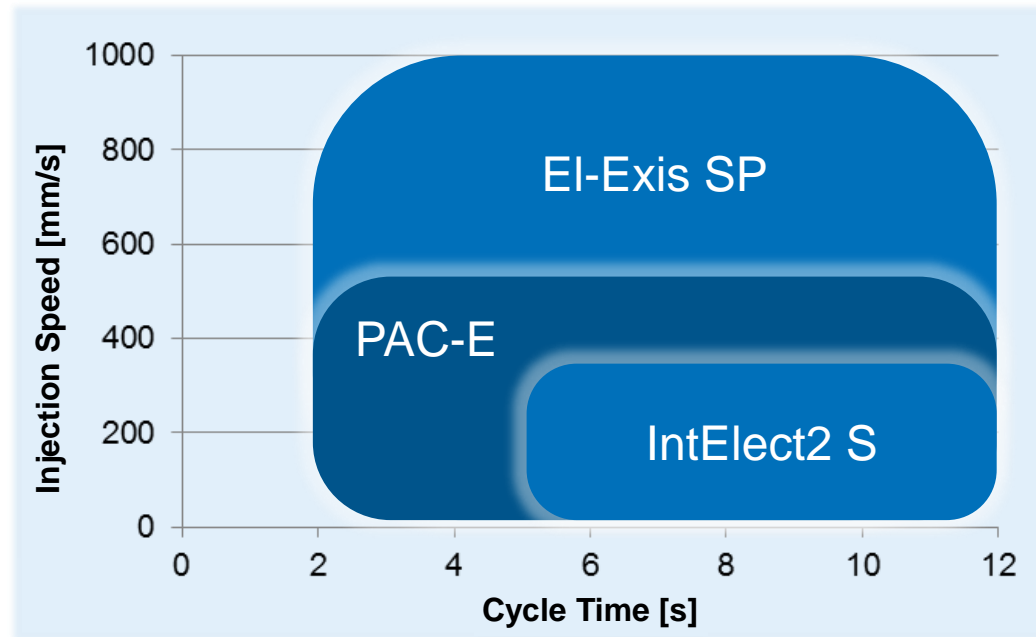

EI-Exis SP

- + Fastest machine on the market
- + Proven & reliable
- Energy consumption
- Cleanliness

IntElect

- + All-electric technology
- + Energy consumption
- Limited in fast cycle times
- Limited injection speed

All-electric market leader

Close to 80.000 all-electric machines in the market

Leading in direct drive technology

In-house drives and controls manufacturing

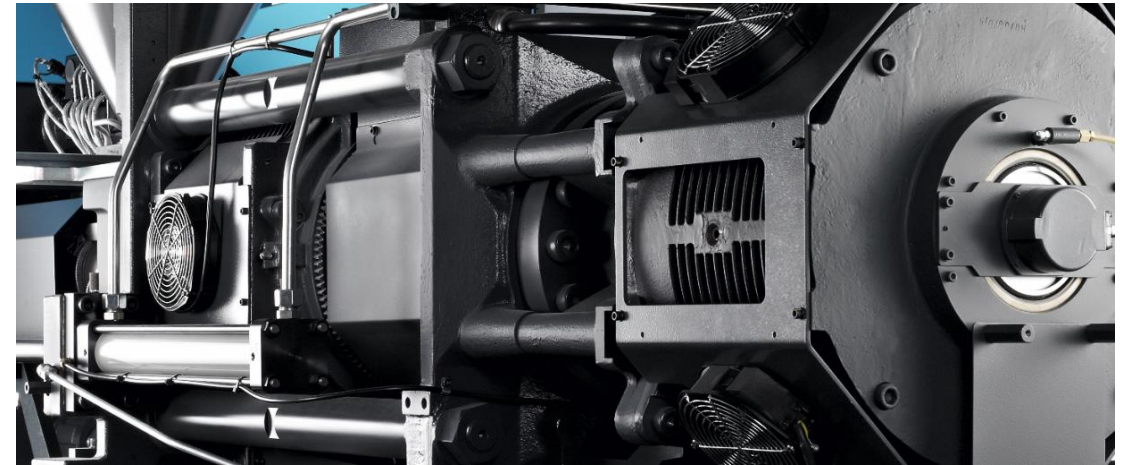



Market leader in packaging

3.500 packaging machines in the market

Dedicated Business Development Team

Focus on applications



PAC-E | The new all-electric high-speed benchmark

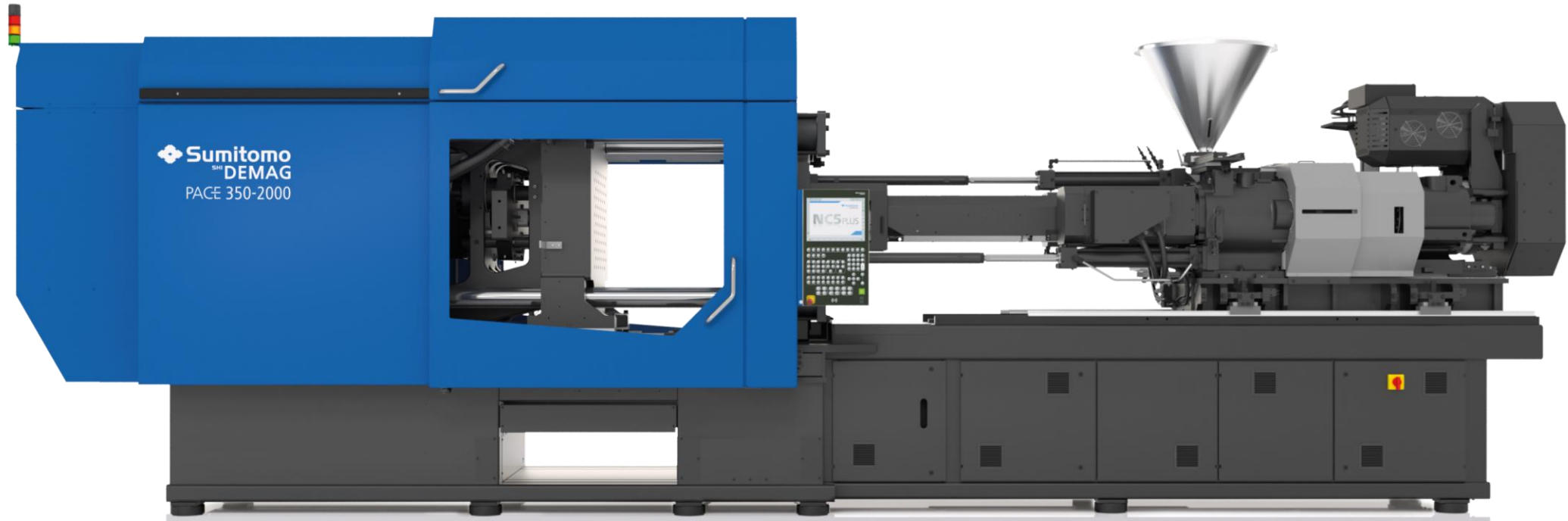

Developed on a global platform

PAC-E | Performance

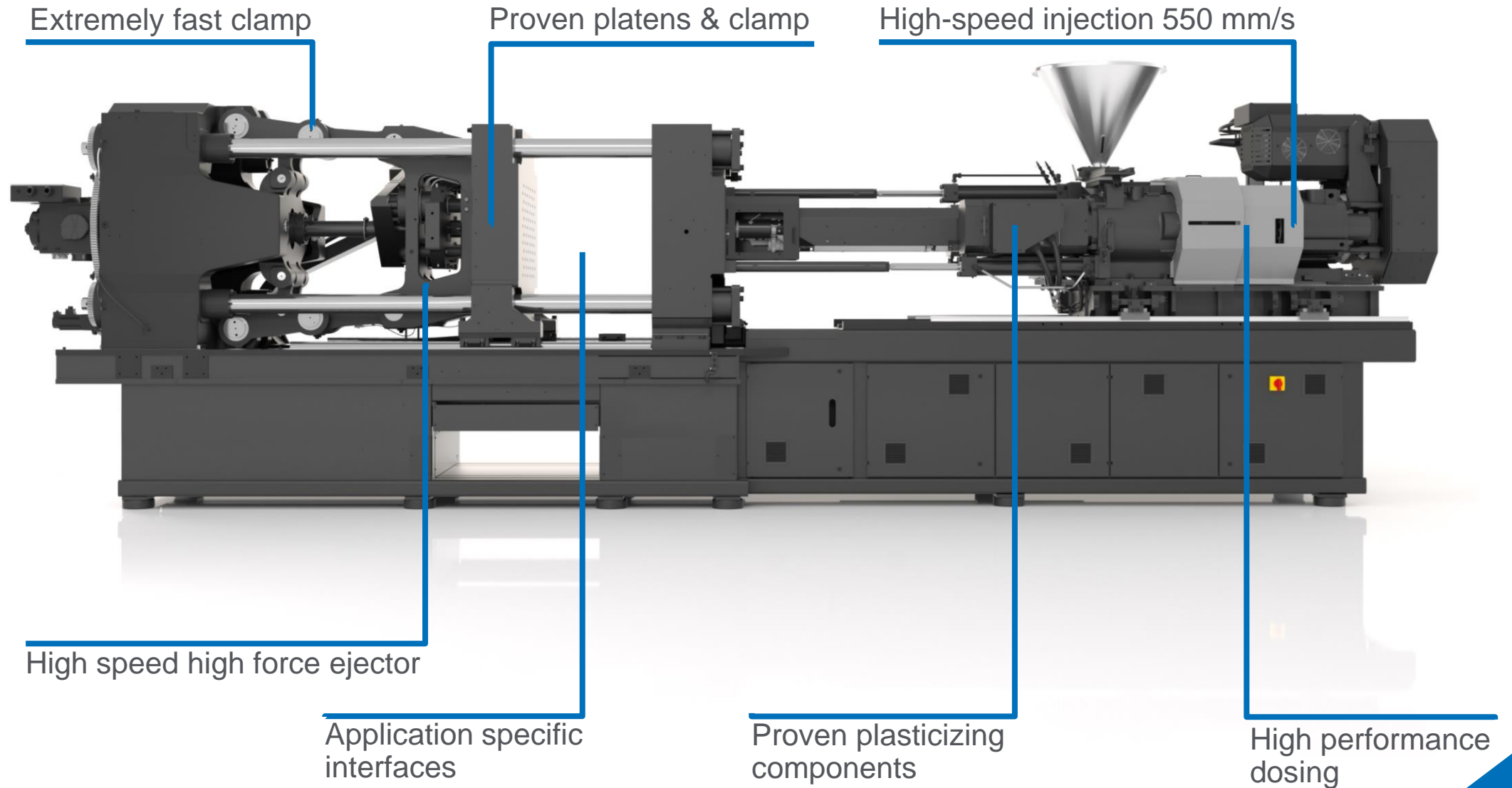

PAC-E | Energy efficiency

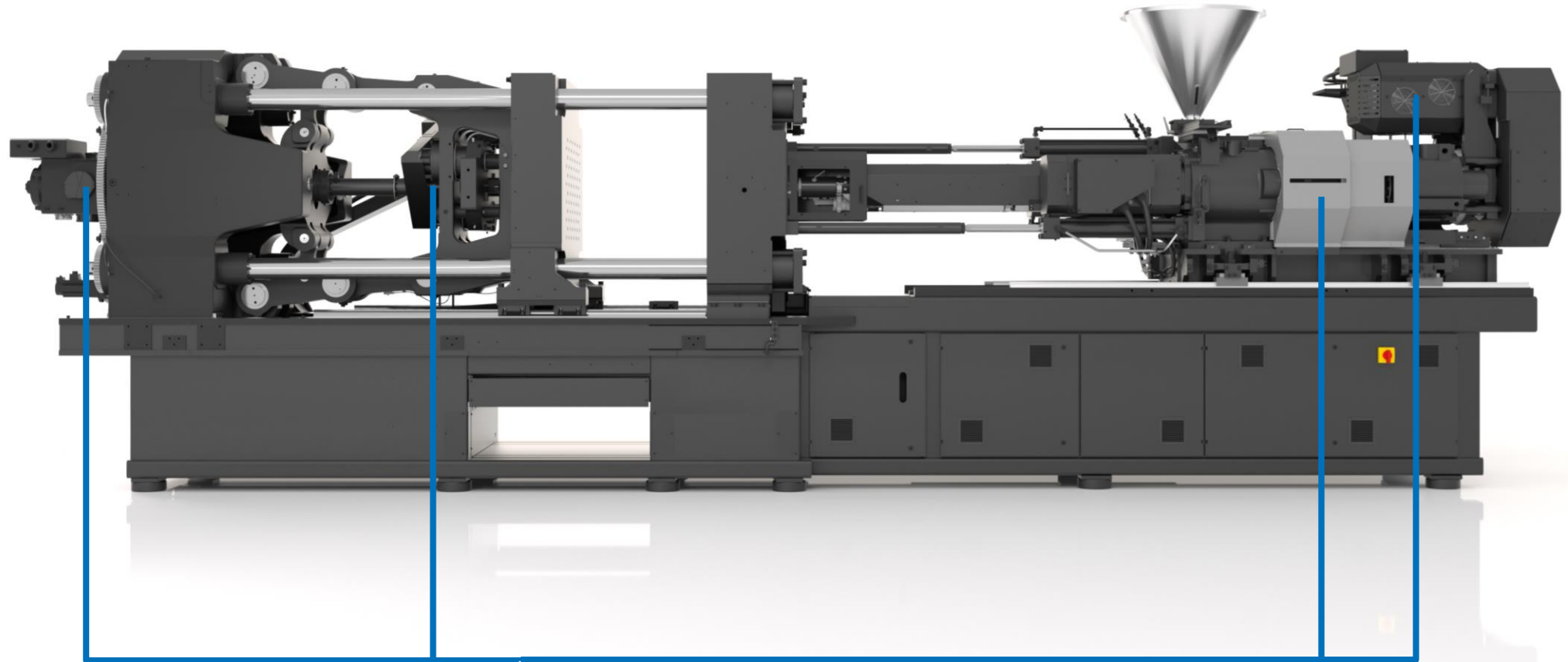

All electric / in house technology

PAC-E | Cleanliness

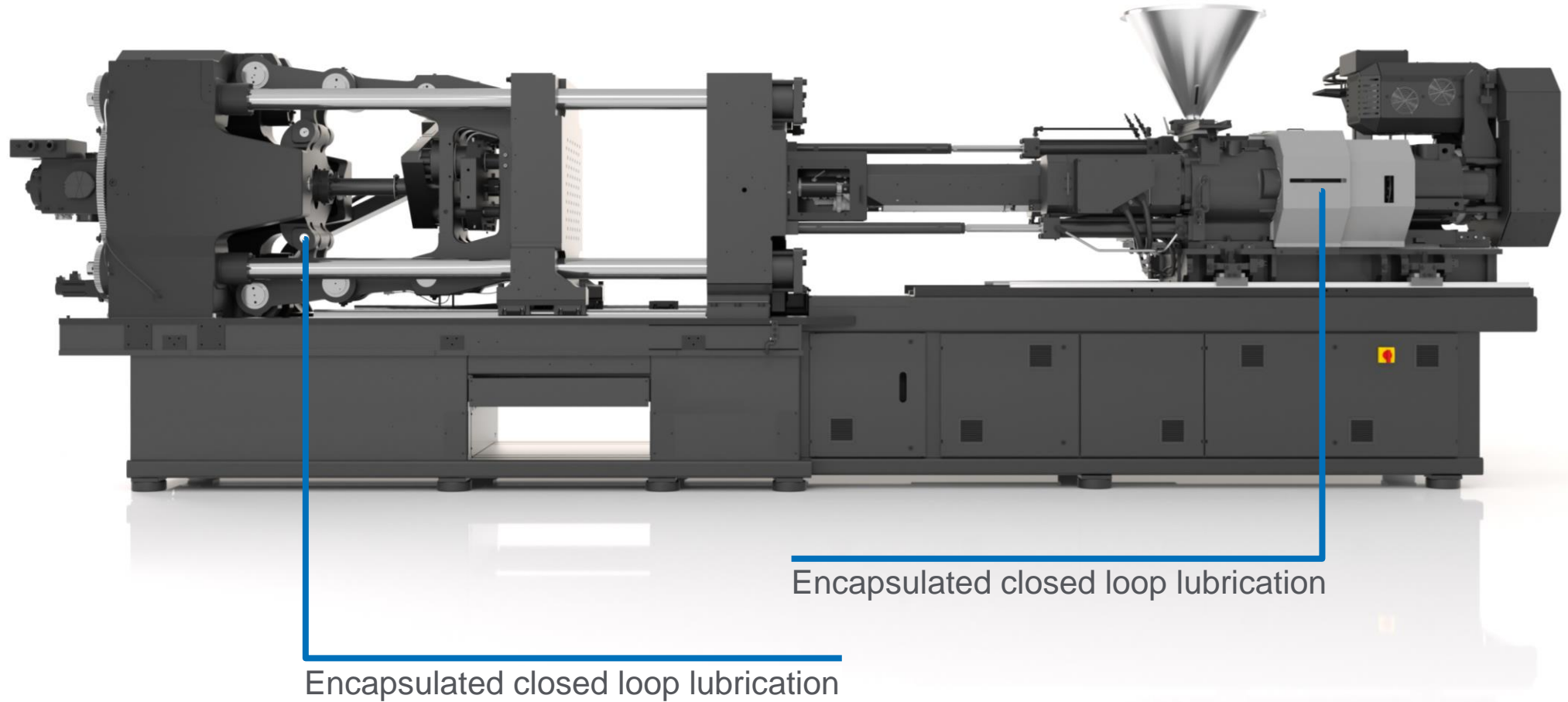

Drinktec | Meet us: hall C5 booth 319

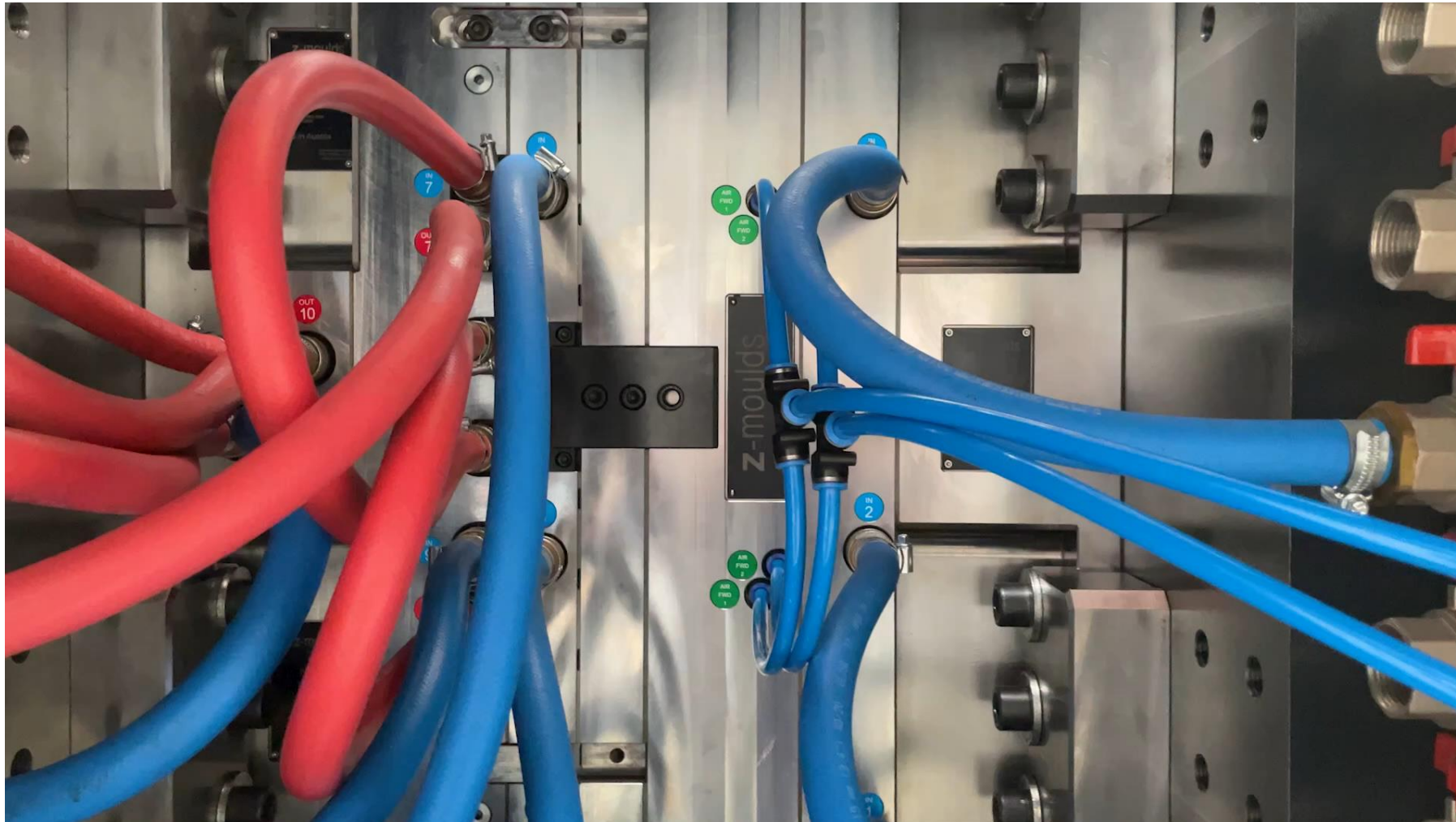

drinktec
Grow with the Flow

Drinktec | Meet us: hall C5 booth 319



Best in class productivity



Best in class energy efficiency



Best in class partners



Schedule a meeting now!



Thank you for your attention

